



200PSI NRS Flanged End Gate Valve

ANI VALVE

P/N : AV-NG-FF200

Resilient Wedge NRS Gate Valve - Flanged End

Technical Features

Nominal Pressure: 200PSI

Flange Standard: ASME / ANSI B 16.1 Class 125 or ASME / ANSI B 16.42 Class 150 or BS EN 1092-2 PN 16 or GB / T9113.1

Sizes: 2 1/2" , 3" , 4" , 5" , 6" , 8" , 10" , 12"

Face to Face Standard : ASME B 16.10

Working Pressure: 200 PSI (Maximum Testing Pressure 400 PSI) conforms to UL 262

Working Temperature Range: 0C°-80C°(32°F-176°F)

Coating Details: Epoxy coated interior and exterior by Electrostatic Spray or coating upon request

NPT plug on body with 2 operating nuts

Certified lead-free by NSF / ANSI 61 & NSF / ANSI 372 is available

Approval: UL

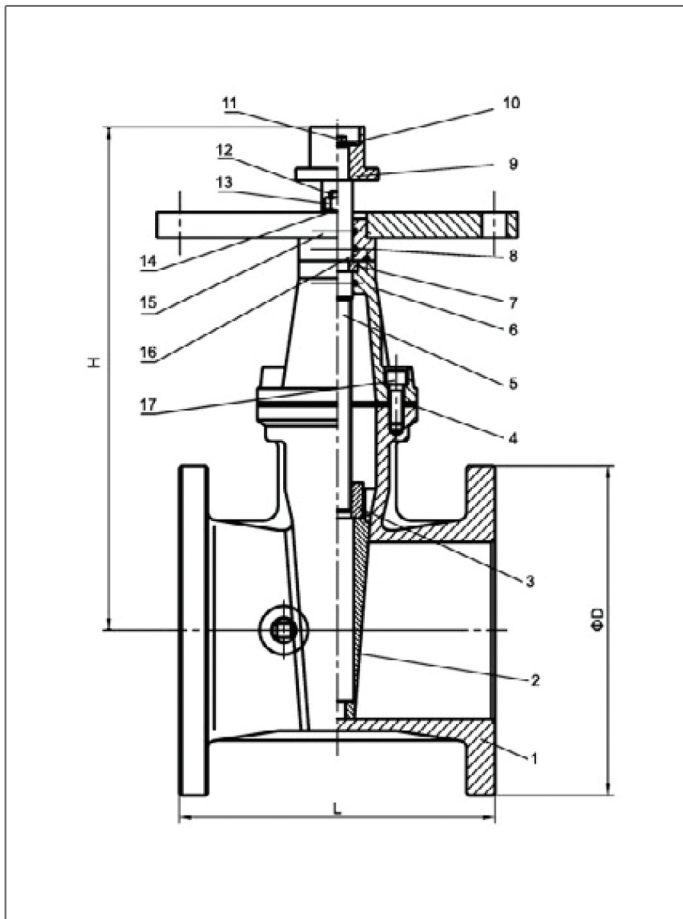

Valve Material List

NO	Name	Material	Standard
1	Body	Ductile Iron	ASTM A536 Grade 65-45-12
2	Disc	Ductile Iron + EPDM	ASTM A536 Grade 65-45-12 +ASTM D2000
3	Nut	C95400	ASTM B148
4	Gasket	EPDM	ASTM D2000
5	Stem	Stainless Steel 304	ASTM A276
6	Cap	Ductile Iron	ASTM A536 65-45-12
7	Retainer Ring	C95400	ASTM B148
8	O ring	EPDM	ASTM D2000
9	Wrench Nut	Ductile Iron	ASTM A536 65-45-12
10	Minipad	Steel 1045	ASTM A29
11	Bolt	Steel 1045	ASTM A29
12	Stud	Steel 1045	ASTM A29
13	Nut	Steel 1045	ASTM A29
14	Flat Washer	Steel 1045	ASTM A29
15	Coupling Flange	Ductile Iron	ASTM A536 65-45-12
16	Platen	Ductile Iron	ASTM A536 65-45-12
17	Countersunk Head Bolt	Steel 1045	ASTM A29

Dimensions

Size	L	H	D
2"	178	265	152
2 1/2"	190	289	178
3"	203	326	191
4"	229	355	229
5"	254	410	254
6"	267	455	279
8"	292	558	343
10"	330	648	406
12"	356	745	483



ANI Group