



300PSI OS & Y Flanged End Gate Valve

ANI VALVE

P/N : AV-OG-FF200

Resilient Wedge OS & Y Gate Valve - Flanged End

Technical Features

Nominal Pressure: 200PSI

Flange Standard: ASME / ANSI B 16.1 Class 125 or ASME / ANSI B 16.42 Class 150 or BS EN 1092-2 PN 16 or GB / T9113.1

Sizes: 2 1/2" , 3" , 4" , 5" , 6" , 8" , 10" , 12"

Face to Face Standard : ASME B 16.10

Working Pressure: 200 PSI (Maximum Testing Pressure 400 PSI) conforms to UL 262

Working Temperature Range: 0C°-80C°(32°F-176°F)

Coating Details: Epoxy coated interior and exterior by Electrostatic Spray or coating upon request

NPT plug on body with 2 operating nuts

Certified lead-free by NSF / ANSI 61 & NSF / ANSI 372 is available

With and Without Post Flange are available

Approval: UL

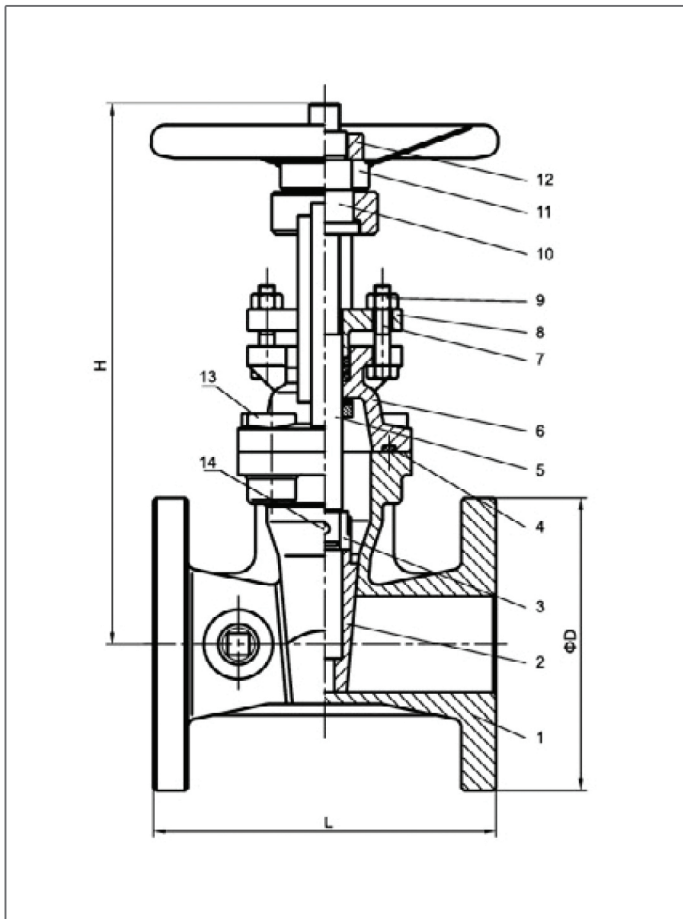

Valve Material List

| NO | Name | Material | Standard |
|----|-----------------------|---------------------|--------------------------------------|
| 1 | Body | Ductile Iron | ASTM A536 Grade 65-45-12 |
| 2 | Disc | Ductile Iron + EPDM | ASTM A536 Grade 65-45-12 +ASTM D2000 |
| 3 | Connecting Part | C95400 | ASTM B148 |
| 4 | Sealing Pad | EPDM | ASTM D2000 |
| 5 | Stem | Stainless Steel 304 | ASTM A276 |
| 6 | Yoke | Ductile Iron | ASTM A536 65-45-12 |
| 7 | Bolt | Steel1045 | ASTM A29 |
| 8 | Gland | Ductile Iron | ASTM A536 65-45-12 |
| 9 | Nut | Steel 1045 | ASTM A29 |
| 10 | Rotating Nut | C95400 | ASTM B148 |
| 11 | Handwheel | Steel 1045 | ASTM A29 |
| 12 | Lock Nut | Steel 1045 | ASTM A29 |
| 13 | Countersunk Head Bolt | Steel 1045 | ASTM A29 |
| 14 | Cylinder Pin | Stainless Steel 304 | ASTM A276 |

Dimensions

| Size | L | H | D |
|--------|-----|------|-----|
| 2" | 178 | 313 | 152 |
| 2 1/2" | 190 | 340 | 178 |
| 3" | 203 | 387 | 191 |
| 4" | 229 | 440 | 229 |
| 5" | 254 | 546 | 254 |
| 6" | 267 | 607 | 279 |
| 8" | 292 | 786 | 343 |
| 10" | 330 | 946 | 406 |
| 12" | 356 | 1110 | 483 |



ANI Group