



200PSI OS & Y FxG End Gate Valve

ANI VALVE

P/N : AV-OG-FG200

Resilient Wedge OS & Y Gate Valve - Flanged X Grooved End

Technical Features

Nominal Pressure: 200PSI

Flange Standard: ASME / ANSI B 16.1 Class 125 or ASME / ANSI B 16.42 Class 150 or BS EN 1092-2 PN 16 or GB / T9113.1

Grooved Standard: Metric or ANSI / AWWA C606

Sizes: 2 1/2" , 3" , 4" , 5" , 6" , 8" , 10" , 12"

Face to Face Standard : ASME B 16.10

Working Pressure: 200 PSI (Maximum Testing Pressure 400 PSI) conforms to UL 262

Working Temperature Range: 0C°-80C°(32°F-176°F)

Coating Details: Epoxy coated interior and exterior by Electrostatic Spray or coating upon request

NPT plug on body with 2 operating nuts

Certified lead-free by NSF / ANSI 61 & NSF / ANSI 372 is available

Approval: UL

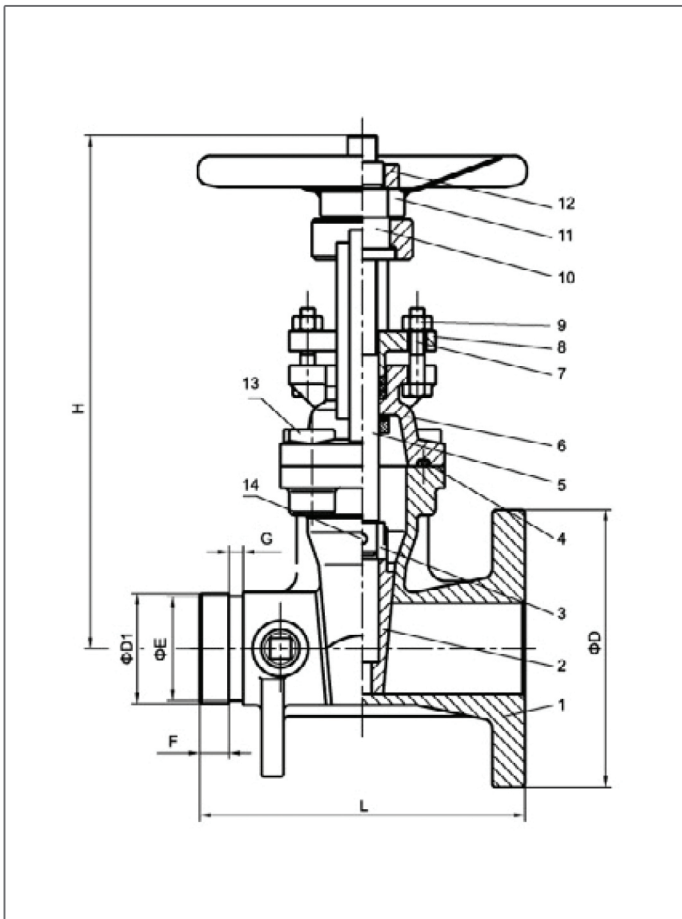
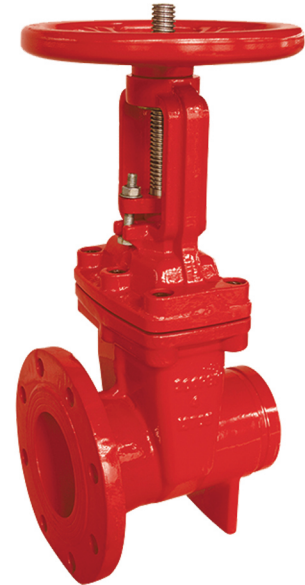

Valve Material List

NO	Name	Material	Standard
1	Body	Ductile Iron	ASTM A536 Grade 65-45-12
2	Disc	Ductile Iron + EPDM	ASTM A536 Grade 65-45-12 +ASTM D2000
3	Connecting Part	C95400	ASTM B148
4	Sealing Pad	EPDM	ASTM D2000
5	Stem	Stainless Steel 304	ASTM A276
6	Yoke	Ductile Iron	ASTM A536 65-45-12
7	Bolt	Steel1045	ASTM A29
8	Gland	Ductile Iron	ASTM A536 65-45-12
9	Nut	Steel 1045	ASTM A29
10	Rotating Nut	C95400	ASTM B148
11	Handwheel	Steel 1045	ASTM A29
12	Lock Nut	Steel 1045	ASTM A29
13	Countersunk Head Bol	Steel 1045	ASTM A29
14	Cylinder Pin	Stainless Steel 304	ASTM A276

Dimensions

Size	L	H	D	D1	E	F	G
2"	178	313	152	60.3	57.2	15.9	7.9
2 1/2"	190	340	178	76.1	72.3	15.9	7.9
3"	203	387	191	88.9	84.9	15.9	7.9
4"	220	440	220	114.3	110.1	16	0.6
5"	254	546	254	141.3	137	15.9	9.5
6"	267	607	279	168.3	163.9	15.9	9.5
8"	292	786	343	219.1	214.4	19	11.1
10"	330	946	406	273	268.3	19	12.7
12"	356	1110	483	323.9	318.3	19	12.7



ANI Group